

FireStingO₂-SubPort

*CUSTOM FIBER-OPTIC OXYGEN METER
UNDERWATER OEM MODULE
FOR DEEP SEA APPLICATION*

MANUAL

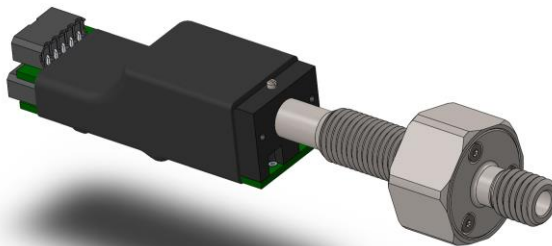

The *FireStingO2-SubPort* is manufactured by

PyroScience GmbH
Hubertusstr. 35
52064 Aachen
Germany

Phone	+49 (0)241 5183 2210
Fax	+49 (0)241 5183 2299
Email	info@pyroscience.com
Internet	www.pyroscience.com

Registered: Aachen HRB 17329, Germany

TABLE OF CONTENT

1	SAFETY GUIDELINES	1
2	OVERVIEW	2
2.1	FIBER CONNECTOR	3
2.2	TEMPERATURE COMPENSATION	4
2.3	SUPPLEMENTARY INTERNAL SENSORS	4
3	INSTALLATION	5
3.1	MOUNTING OF FIBER CONNECTOR IN THE HOUSING	5
3.2	ASSEMBLY OF THE FIRESTINGO ₂ -SUBPORT	6
3.3	ELECTRICAL CONNECTORS	7
3.3.1	<i>Connector X1: Power + Digital Interface</i>	8
3.3.2	<i>Connector X2: Analog Output</i>	9
3.3.3	<i>Pt100 Terminal</i>	10
4	UART-INTERFACE	10
4.1	FULL-CONTROL MODE	10
4.2	AUTO-MODE	11
5	USB-INTERFACE CABLE	13
5.1	SOFTWARE INSTALLATION	14
5.2	USING THE PYRO OXYGEN LOGGER SOFTWARE	14
6	CONNECTING OXYGEN SENSORS	15
7	SPECIFICATIONS	17
8	DIMENSIONS	19

1 Safety Guidelines

Please follow the appropriate laws and guidelines for safety like EEC directives for protective labor legislation, national protective labor legislation, safety regulations for accident prevention and safety data-sheets from manufacturer of chemicals used during measurements.

Before using the *FireStingO2-SubPort* and its sensors, read carefully the instructions and user manuals.

In case of problems or suspected damage, do not use the device and mark it to prevent any further use! Consult *Pyro Science* for advice! There are no serviceable parts inside the device. Please note that opening the device (e.g. removing the shrink tube) void the warranty!

The *FireStingO2-SubPort* is not intended for medical or military purposes or any safety-critical applications.

The device should be installed and used only by qualified personal following the user instructions and the safety guidelines of the manual, as well as the appropriate laws and guidelines for safety!

It is possible, that an underwater enclosure is partly flooded during deployment and reseals before it is brought to surface. The result can be potentially dangerous internal pressure. If you suspect your device has been flooded, point the *FireStingO2-SubPort* connectors away from persons and valuable equipment. Release the pressure in a way appropriate for your specific housing.

2 Overview

The *FireStingO2-SubPort* is an OEM solution for fiber-optic oxygen measurements under water. It is designed for integration into custom-made underwater housings. The *FireStingO2-SubPort* consists of two parts. A special version of the *FireStingO2-Mini* oxygen meter, and a pressure stable optical connector (Fig. 1). It can be used for many different applications like water column and sediment profiling, eddy covariance studies, etc.

The *FireStingO2-SubPort* is easy to mount and can also be used to retrofit existing underwater equipment since its thread is compatible to some of the most popular deep-sea connectors. The titanium connector is open face pressure stable up to 4000 m water depth (400 bars). It is typically mounted in the lid of pressure cylinders (Fig. 2).

A serial interface allows to control the instrument and to retrieve data. Additionally, high-resolution analog outputs can be used.

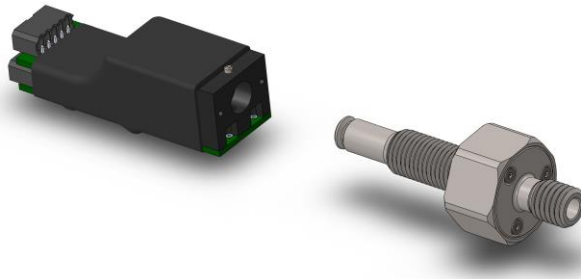

Fig. 1 The *FireStingO2-SubPort* comprises a special version of the *FireStingO2-Mini* (left) and a pressure-stable fiber-optic connector (right)

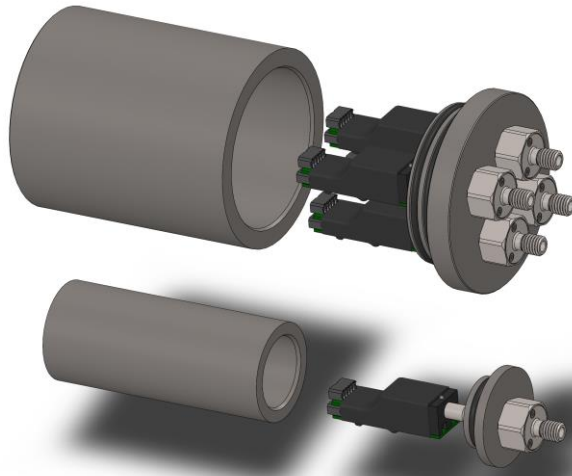

Fig. 2 Mounting examples for a 4-channel and 1-channel measuring system based on the FireStingO2-SubPort.

Additional information about the optical oxygen measuring principle can be found in the manual of the USB-device *FireStingO2*.

2.1 Fiber Connector

The *FireStingO2-SubPort* is compatible with special *PyroScience* fiber-optic sensors for underwater applications designated by the appendix "-SUB" in the item number. A broad range of compatible sensor heads are available with tip diameters ranging from ca. 50-70 μm up to 430 μm (microsensors and minisensors). Refer to the *PyroScience* webpage for further details. The sensors can be easily installed and exchanged in the field without any tools.

2.2 Temperature Compensation

The oxygen measurement is generally temperature dependent. To obtain accurate oxygen readings, the water temperature needs to be measured at the same time. The *FireStingO2-SubPort* provides built-in temperature compensation using an internal temperature sensor or an attached external sensor. Although the internal temperature sensor can be used for compensation under certain circumstances, the first choice should always be an external sensor placed close to the oxygen sensor (see chapter 3.3.3).

Temperature compensation can also be performed in data post-processing using independent temperature measurements. Please contact *PyroScience* for details.

2.3 Supplementary Internal Sensors

Besides the very oxygen sensor, the *FireStingO2-SubPort* provides three other built-in high precision sensors:

- (1) internal **atmospheric pressure sensor** for measuring the ambient air pressure
- (2) internal sensor for measuring the **relative humidity** of the ambient air
- (3) **internal temperature sensor** measuring the temperature of the ambient air

In typical applications, these three sensors will not be used since they are inside the pressure housing and thus provide no information about the environment. They are present because the *FireStingO2-SubPort* is a special version of the more generic *FireStingO2-Mini* module. The pressure and the humidity sensors will give reliable data about the ambient air of the module. The readings of the internal temperature sensor should be interpreted more carefully. Internal heating by the electronics

typically increases the internal temperature by about 1°C , depending on operation conditions.

3 Installation

3.1 Mounting of Fiber Connector in the housing

The fiber connector can be installed in two ways, depending on the housing. In thick-walled housings, the connector can be screwed directly into a threaded hole. For thinner walls, fixing the connector with the supplied hex nut is possible (Fig. 3). In both cases, the tightening force should not exceed 12 Nm. Note that the sealing surface must be smooth to ensure a good sealing. The O-ring should be lubricated with a thin layer of silicone grease before installation. The screw joint can be secured with bold adhesive, e.g. Loctite™243. Recommendations for the mounting hole can be found in Fig. 3.

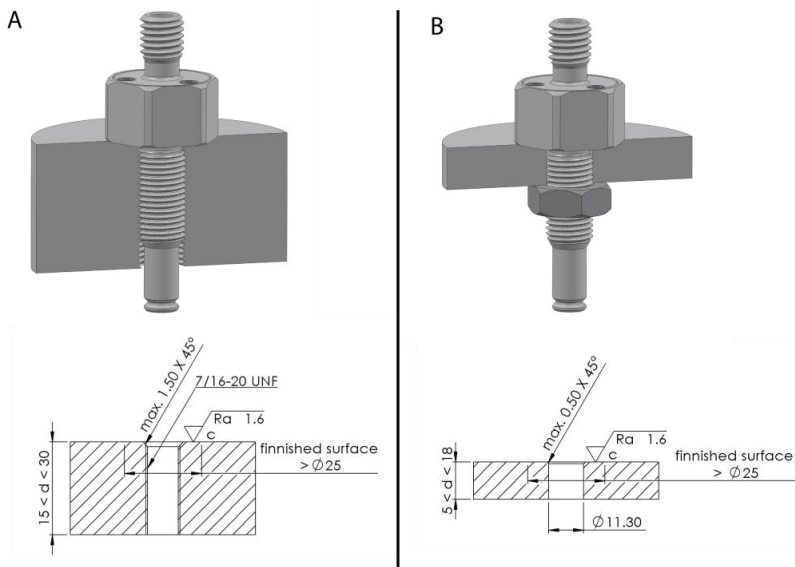

Fig. 3 Mounting options

Pressure tests of the whole assembly prior to deployment are strongly advised!

3.2 Assembly of the FireStingO2-SubPort

After the fiber optic connector is installed in the lid of the pressure housing, it can be mounted to the *FireStingO2-Mini* module (Fig. 4). The connector is inserted into the *FireStingO2-Mini*, with moderate force, as far as it will go. The angular position can be freely chosen. It is fixed in place with a set screw. Note that the housing lid was omitted in Fig. 4 for clarity.

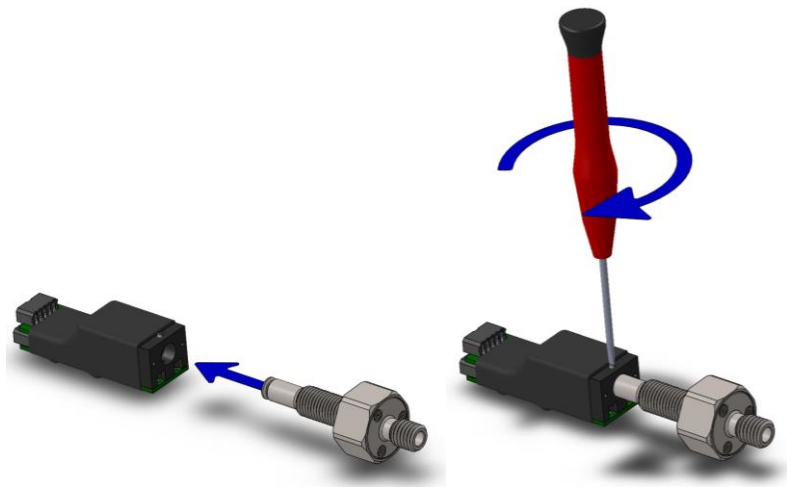

Fig. 4 Assembly of *FireStingO2-SubPort*

3.3 Electrical Connectors

The electrical interface of the *FireStingO2-SubPort* consists of the two receptacles X1 and X2 (Fig. 5). The package includes the connector plugs S1 and S2, also available from "Phoenix Contact" item no. 1778887 and 1778861. Stripped cable ends can be connected to S1 and S2 without any soldering or crimping. When inserting or removing a stripped cable end (stripping length 6 mm, max. core diameter 0.5 mm²), an internal spring mechanism has to be unlocked by pushing relatively strong with a small screw-driver (flat-bladed 2mm in width) into the adjacent rectangular hole.

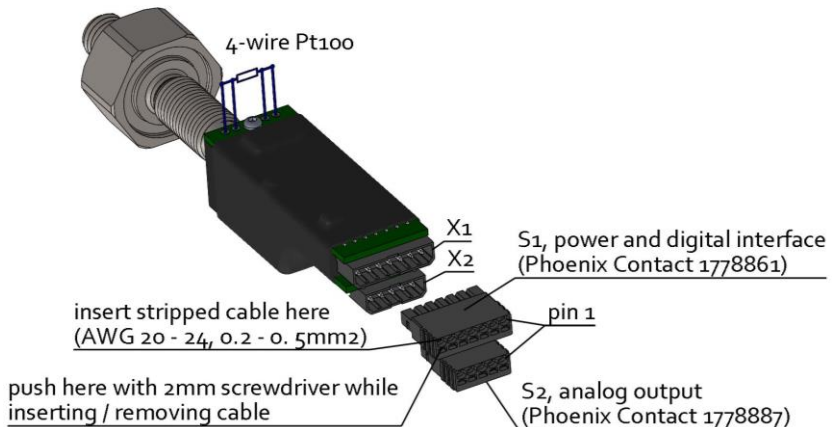

Fig. 5 Electrical connectors of the FireStingO2-Mini

3.3.1 Connector X1: Power + Digital Interface

The pin configuration of the connector X1 is given in Tab. 1. Pins 1-3 are for the power supply of the module. Transmit and receive lines of the UART-interface are given at pins 4+5. The additional pins 6+7 are only needed if the module is operated in auto-mode (see following chapter). In standard operation mode both pins 6+7 should be left unconnected.

Pin	Name	Function	Description
1	GND	Power	Ground
2	VCC	Power	Power supply min. 3.5V max. 5.0V DC max. 50 mA (typical 30 mA)
3	GND	Power	Ground
4	TXD	Digital Output (0V or 3.3V)	Data transmission pin of the UART interface
5	RXD	Digital Input (0V or 3.3V) (5V tolerant)	Data receive pin of the UART interface
6	/AUTO	Digital Input (0V or 3.3V, internally pulled- up to 3.3V)	Leave auto-mode pin unconnected for normal operation. Connect to GND for auto-mode operation.
7	/TRIG	Digital Input (0V or 3.3V, internally pulled- up to 3.3V)	Trigger input for triggering a measurement in "triggered auto-mode". The trigger is activated at the moment, when the unconnected pin is tied to GND.

Tab. 1 Pin configuration of connector X1

3.3.2 Connector X2: Analog Output

The connector X2 provides 4 independent analog outputs with a range of 0-2.5V DC at a resolution of 14 bits (Tab. 2). The 4 analog outputs can be configured by the UART communication protocol very flexible. The parameter provided at each analog output can be chosen (e.g. oxygen concentration in different units, signal intensity of the oxygen sensor, ambient pressure, ambient humidity, internal temperature, external temperature from PT100), the scaling can be adjusted freely, and even an alarm function can be configured. If an analog output is configured as an alarm output, it will give 2.5V if a specific parameter is out of a defined range (and 0V if it is within this range).

For further details please refer to the separately available communication protocol.

Pin	Name	Function	Description
1	GND		Ground
2	AO_A	Analog Output (0 – 2.5 V DC) (14 bit resolution)	Analog Output Port A (alternatively digital alarm output)
3	AO_B	Analog Output (0 – 2.5 V DC) (14 bit resolution)	Analog Output Port B (alternatively digital alarm output)
4	AO_C	Analog Output (0 – 2.5 V DC) (14 bit resolution)	Analog Output Port C (alternatively digital alarm output)
5	AO_D	Analog Output (0 – 2.5 V DC) (14 bit resolution)	Analog Output Port D (alternatively digital alarm output)

Tab. 2 Pin configuration of connector X2

3.3.3 Pt100 Terminal

The *FireStingO2-SubPort* provides a high-precision sensor interface which can be directly connected to any standard 4-wire Pt100. The Pt100 has to be soldered directly to the electronics board of the module (Fig. 5).

NOTE: In order to minimize potential electrical noise coupling into the external temperature sensor, the 4-wire cable should be twisted and as short as possible. Cable lengths above 2m are not recommended.

4 UART-Interface

The *FireStingO2-SubPort* is operated via a standard UART interface at 3.3V levels (5V tolerant) consisting of a receive and a transmit line (connector X1, pins 4+5, see Tab. 1). The configuration of the UART-interface is as follows:

19200 baud, 8 data bit, 1 stop bit, no parity, no handshake

The baud rate can be changed by a special command. Please refer to the communication protocol for further information. However, after power cycling the module always reverts to the standard baud rate of 19200.

There are two principal operation modes possible: (1) the full-control mode and (2) the auto-mode. Please note that adjusting the settings and performing any calibration can only be done in the full-control mode.

4.1 Full-Control Mode

The standard operation mode of the module is the full-control mode. The necessary electrical connections are shown in Fig. 6.

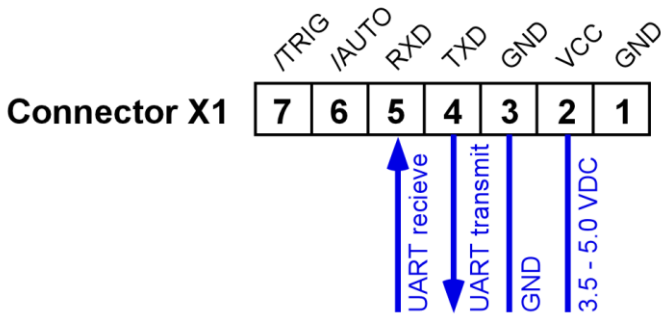

Fig. 6 Pin assignment in full-control mode

The full-control mode allows exploiting the full functionality of the module. Each action of the module is triggered by transmitting a text command via the UART interface. The measurement results can be read out via the same UART interface. Alternatively, measurement results can be also read from the analog outputs.

For further details please refer to the separately available communication protocol.

4.2 Auto-Mode

In the full-control mode each single measurement has to be triggered by a specific command sent via the UART interface (e.g. the MSR- or TMP-commands for measuring oxygen or temperature, respectively). Alternatively, an auto-mode can be activated by connecting pin 6 of connector X1 to ground (Fig. 7).

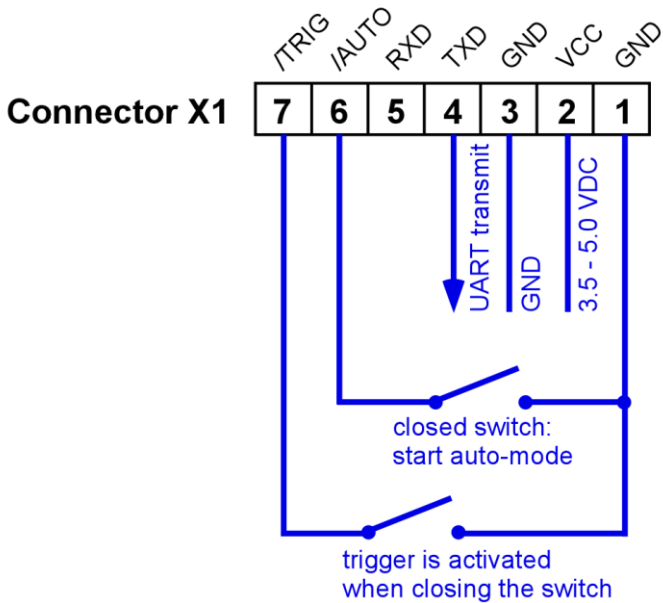

Fig. 7 Pin assignment in auto-mode

The auto-mode offers the possibility (i) that the measurements are automatically triggered periodically by an internal timer (interval auto-mode) or (ii) that the measurements are triggered each time when pin 7 of connector X1 is tied to ground (triggered auto-mode). The results of the measurements can be either read from the transmit pin of the UART interface, or from the analog outputs at connector X2.

NOTE: When the auto-mode is activated, the receive pin of the UART interface has no function. The module will not respond to any command sent to it.

The basic idea behind the auto-mode is that a fully configured and calibrated module can be operated without the need of complex communication protocols. However, the configuration (including the configuration of the auto-mode!) and the

calibration data have to be adjusted in the full-control mode or by using the USB-interface cable in combination with the comfortable windows software *FireSting Logger* (see chapter 5). The communication protocol offers a special command for storing the current configuration and calibration data permanently in the internal flash memory. Thus, a fully configured module can be operated in auto-mode even if the power supply is intermediately interrupted.

A typical application scenario would be the following: the *FireStingO2-SubPort* is configured and calibrated in a "calibration lab" using the full-control mode or the windows software *FireSting Logger*. Configuration and the calibration data are stored in the internal flash memory. Then the sensor is brought to the "field application" which can be a remote place. By connecting pin 6 of the connector X1 to ground, the module starts measuring without the need of any UART communication. The measurement results can be read out as voltages from the analog outputs or as text-string from the UART transmit line.

For further details please refer to the separately available communication protocol.

5 USB-Interface Cable

To operate the *FireStingO2-SubPort* with a Windows PC, use the USB-interface cable *FSO2-MINI-USB* available from *PyroScience*. It includes a license for the comfortable oxygen logger software *Pyro Oxygen Logger* (see below). Additionally, the USB-interface cable provides a virtual COM-port. Custom Windows software can use this virtual COM-port to communicate directly with the module corresponding to the full-control mode described in the chapter 4.1.

5.1 Software Installation

System requirements: PC with Windows 7/8/10 and min. 700 MB free disk space.

IMPORTANT: Do not connect the USB-interface cable *FSO2-MINI-USB* to your PC before the *Pyro Oxygen Logger* software has been installed. The software will install the appropriate USB-drivers automatically.

Installation steps:

- Download the correct software in the downloads tab of your purchased device on www.pyroscience.com
- unzip and start the installer, and follow the instructions
- after the successful installation a new program group "Pyro Oxygen Logger" is added to the start menu, and a short-cut named "Oxygen Logger" can be found on the desktop
- connect the USB-interface cable *FSO2-MINI-USB* to the connector X1 of the *FireStingO2-SubPort*
- connect the cable to a USB-port of the PC. The optical port of the *FireStingO2-SubPort* should flash shortly, indicating the correct startup.
- Start the *Pyro Oxygen Logger* software.

5.2 Using the Pyro Oxygen Logger software

IMPORTANT: The following instructions are only valid for the versions ≥ 3.20 of the *Pyro Oxygen Logger* software. If you have an older version, please download and install the newest version.

Please refer to the *FireStingO2* manual provided with the software for general operation instructions.

The *Pyro Oxygen Logger* software can be used to operate the *FireStingO2-SubPort* with a PC. It can also be used for convenient configuration (settings window) and calibration (calibration window) of the device for embedded applications. All special features including analog output and auto-mode can be configured with an intuitive user interface. The actual logger settings and the calibration data are automatically saved in the internal, non-volatile flash memory of the device each time the logger software is closed.

To configure also the Auto-Mode, press **Prepare Auto-Mode** in the settings window (simple settings, only for "interval auto-mode") or **Advanced Auto-Mode...** (advanced settings, allowing also "triggered auto-mode").

Such a configured module can be used directly in auto-mode (see chapter 4.2). Using it in full-control mode is also possible. Only the commands to trigger measurements and retrieve results are then necessary since configuration and calibration are already stored in the module.

6 Connecting Oxygen Sensors

The *FireStingO2-SubPort* is compatible with special fiber-optic oxygen sensors for underwater applications designated by the appendix "-SUB" in the item number. A broad range of compatible sensor heads are available with tip diameters ranging from ca.50-70 μm , 430 μm , to 3mm (microsensors, minisensors, robust probes). Refer to the *PyroScience* webpage for further details.

An index matching liquid inside the connector enhances the sensor signals. Before connecting a sensor, insert a syringe needle to the bottom of the connector and fill it completely with

deionized water. Alternatively, a drop of silicone oil on the face of the sensor plug can be used. The sensor is inserted and secured with the cap nut (Fig. 8). Do not use a wrench. It is sufficient to tighten the nut by hand.

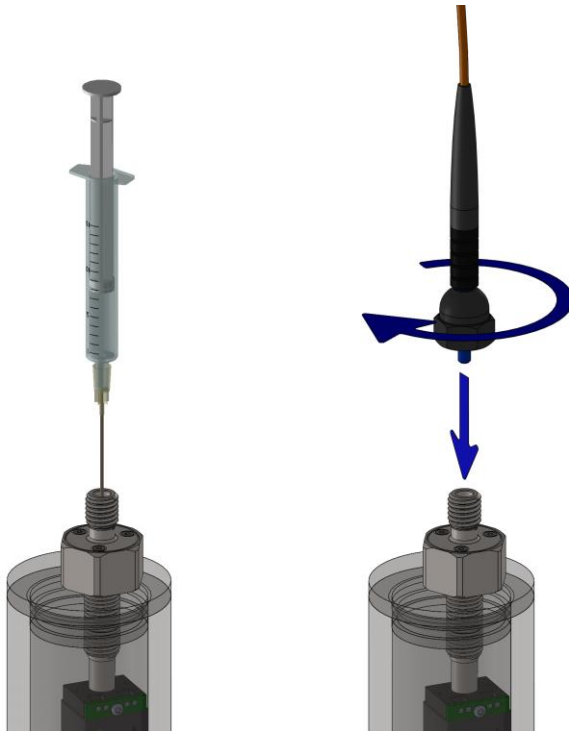

Fig. 8 Connection of sensors

7 Specifications

General Specifications	
Maximum hydrostatic pressure	400 bar
Material fiber optic connector	Titanium (3.7035)
Weight in air	115 g
Operating temperature	0 to 50°C
Storage temperature	-20 to 70°C
Max. relative humidity	Non-condensing conditions
Serial Interface	UART (3.3V level, 5V tolerant)
Power Supply	min. 3.5 V max. 5.0V DC max. 50 mA (typical 30 mA)
Oxygen Sensor	
Oxygen measuring principle	lifetime detection of REDFLASH indicator luminescence
Excitation wavelength	620 nm (orange-red)
Detection wavelength	760 nm (near infrared)
Max. sample rate	ca. 20 samples per second (ext. temperature sensor not activated) ca. 4 samples per second (ext. temperature sensor activated)
For further specifications of the oxygen sensors refer to the separately available specifications for the respective oxygen sensor	
External Temperature Sensor	
Type	PT100 (not included)
Connection	Twisted 4-wire cable, max. 2m in length (optional with coaxial shielding connected to ground)

Resolution	0.02°C
Accuracy	±0.2°C
Range	-30 to 150°C
Internal Temperature Sensor	
Resolution	0.01°C
Accuracy	±0.3°C
Range	-40 to 125°C
Response Time	ca. 1 minute
Internal Humidity Sensor	
Resolution	0.04% rel. humidity
Accuracy	typ. ±0.2% rel. humidity
Range	0 to 100% rel. humidity
Response Time (t63%)	ca. 10 s
Internal Pressure Sensor	
Resolution	0.06 mbar (hPa)
Accuracy	typ. ±3 mbar (hPa)
Range	300 to 1100 mbar (hPa)
Response Time	Instant
Analog Outputs	
Resolution	0.15 mV
Accuracy	typ. ±0.3 mV
Range	0 to 2500 mV

8 Dimensions

